

Installation Readiness of LSS in IR8

1. Magnet availability
2. Cold vacuum system
3. Cold powering
4. Interconnections
5. Infrastructure
6. Conclusions

R. Ostojic, TCC 3 June 2005

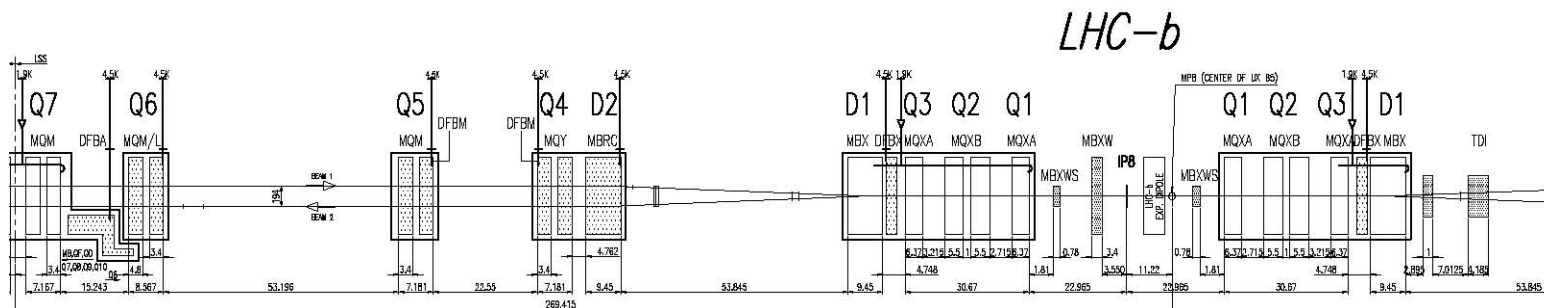
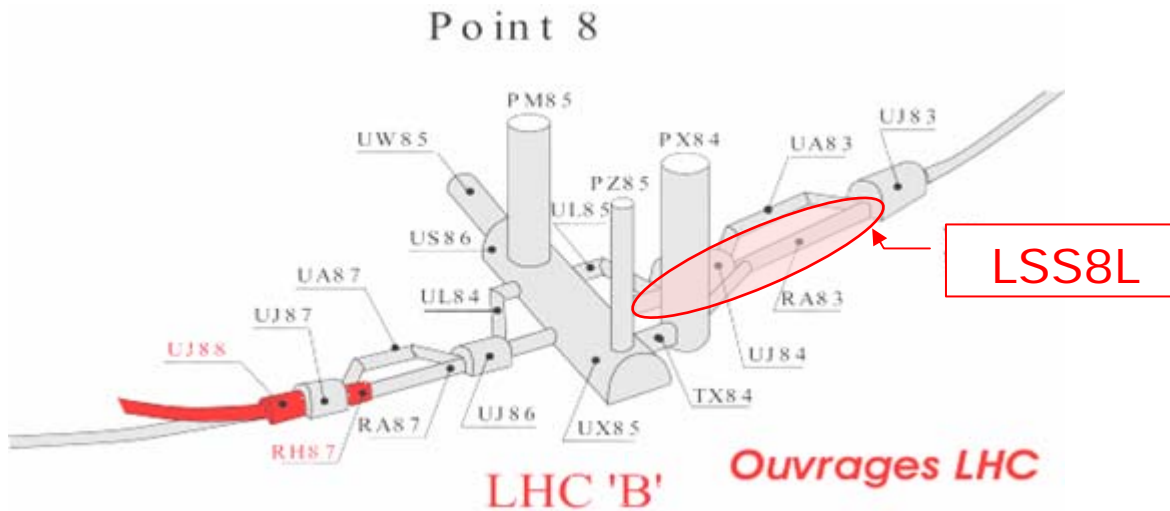

IR8L:		SMI2	MEB
Element	Installation date		
Q1-Q2-Q3	18.08.05	1.07.05	1.06.05
DFBX, D1	07.10.05	1.09.05	D1 (OK)
D2-Q4			D2 (OK)
Q5,Q6	10.10.05	1.09.05	1.08.05
DFBM			
Interconnect	10.10.05		
Q7-Q11	01.02.06		
IR8R:			
Q1-Q2-Q3	19.08.05	1.07.05	1.06.05
DFBX, D1	05.12.05	15.10.05	D1 (OK)
D2-Q4			D2 (OK)
Q5,Q6	12.12.05	15.10.05	1.09.05
DFBM			
Interconnect	12.12.05>		
Q7-Q11	01.02.06	15.12.05	1.11.05

Delivered and accepted magnets at CERN:

- ➔ 5/5 D1
- ➔ 8/9 D2
- ➔ 1/3 D4
- ➔ 1/3 D3
- ➔ 4/9 Q1
- ➔ 3/9 Q2
- ➔ 1/9 Q3 (damage in transport). Q3-02 to arrive in June 05.



- ➔ Check availability of components and tooling.
- ➔ Assemble interconnects, check tooling and procedures.
- ➔ Perform instrumentation and continuity checks for the string from DFBX
- ➔ Mount and check alignment equipment.
- ➔ Check string behaviour under insulation vacuum.
- ➔ Check handling equipment.







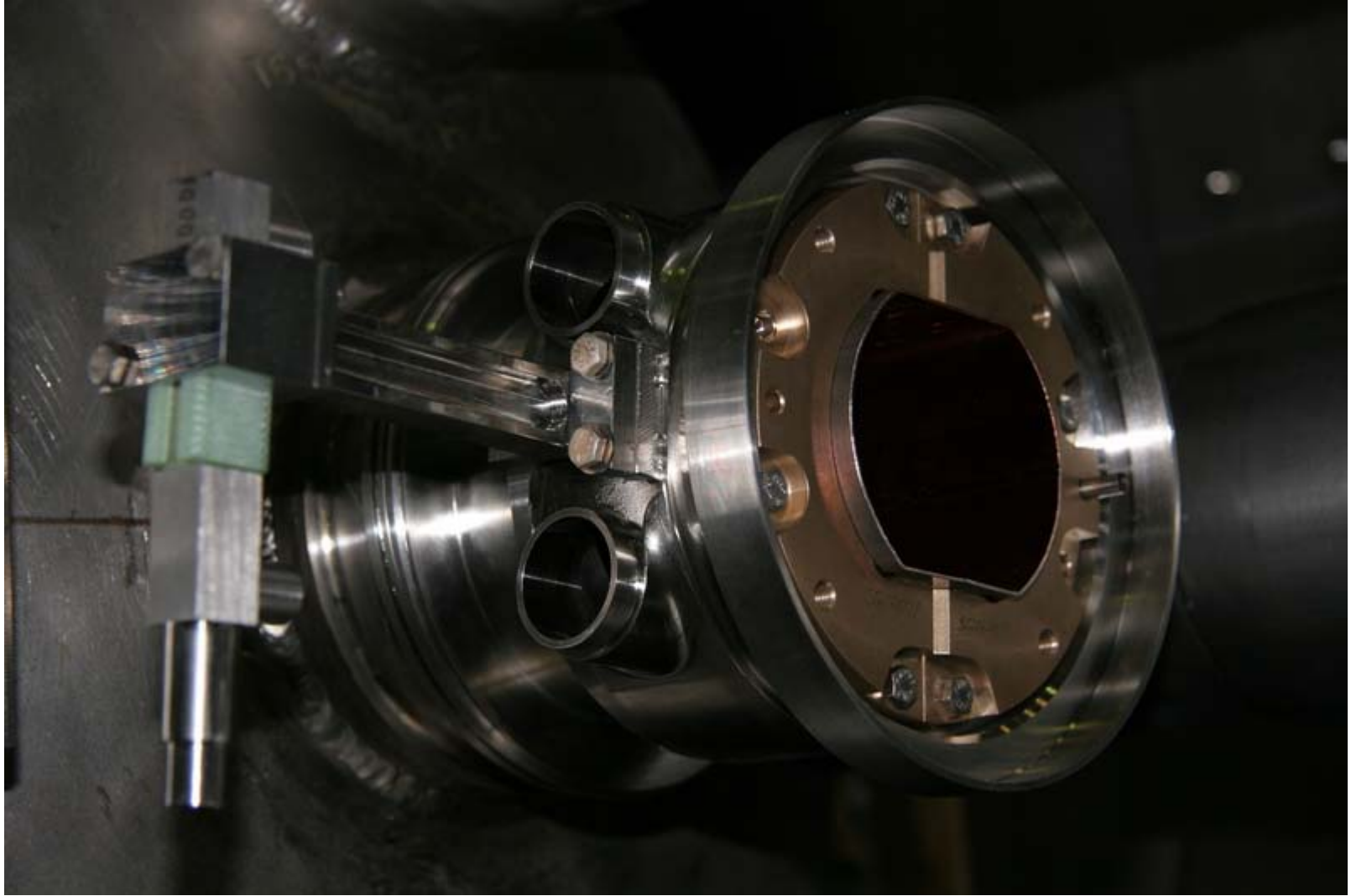

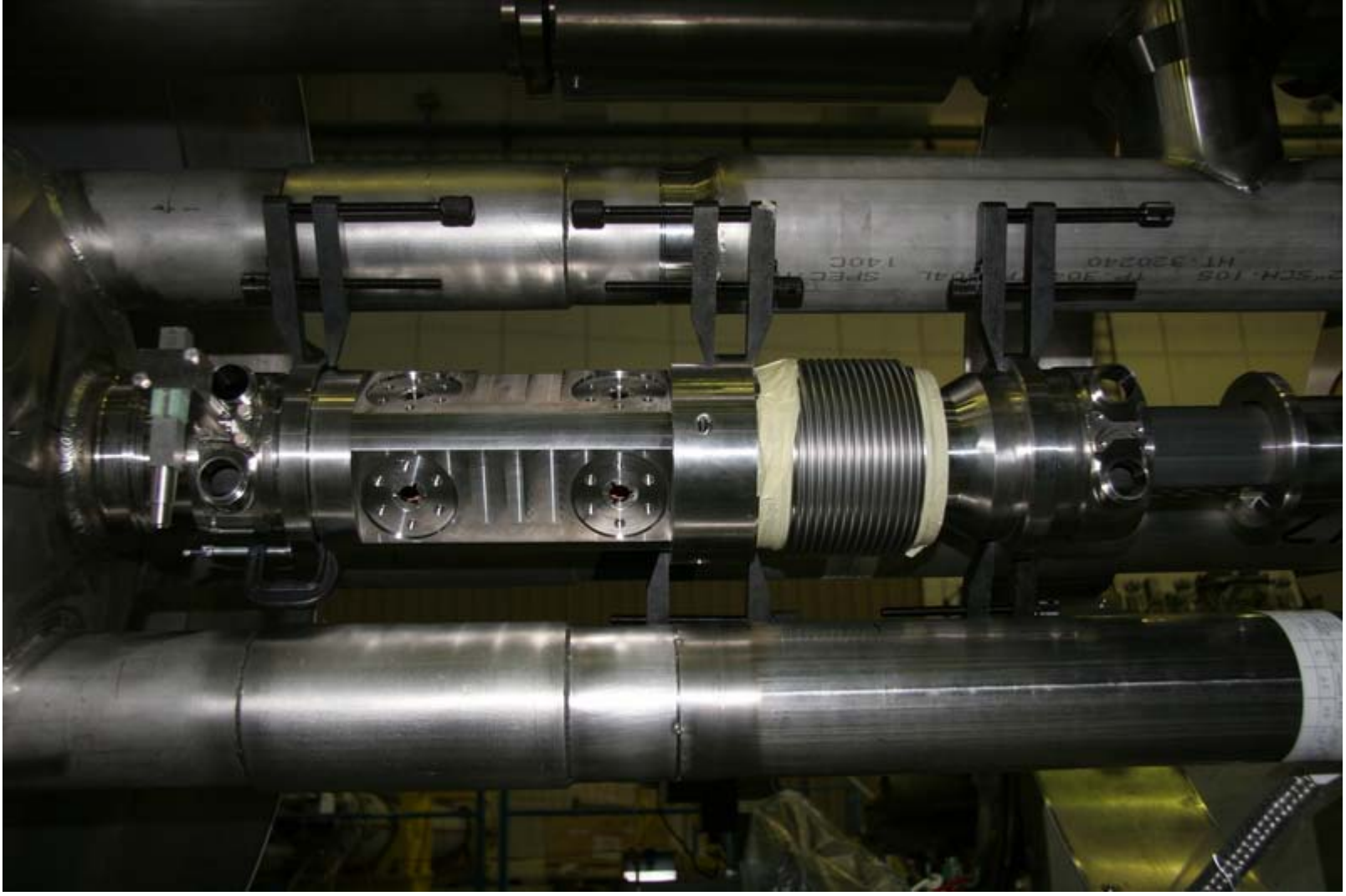



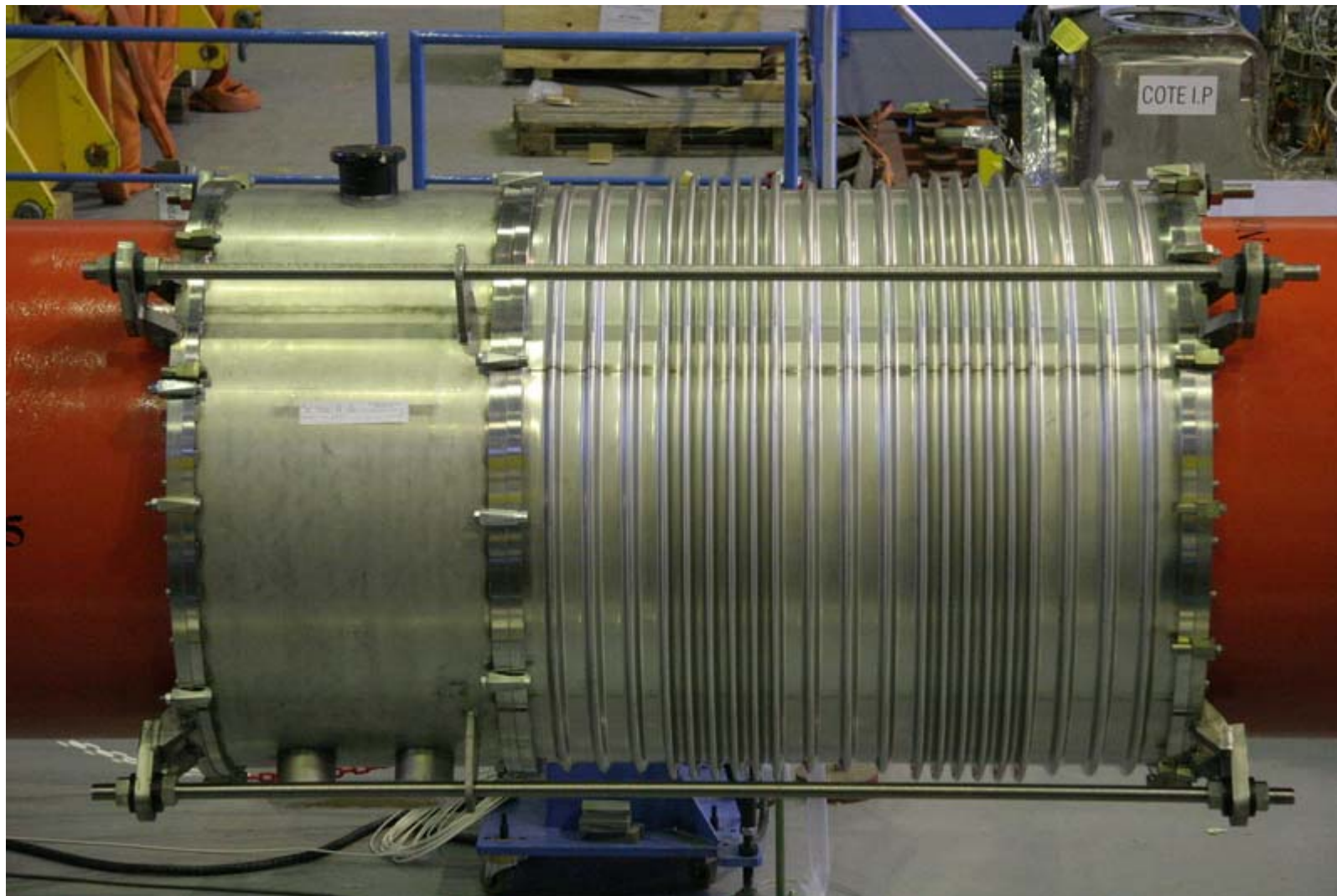





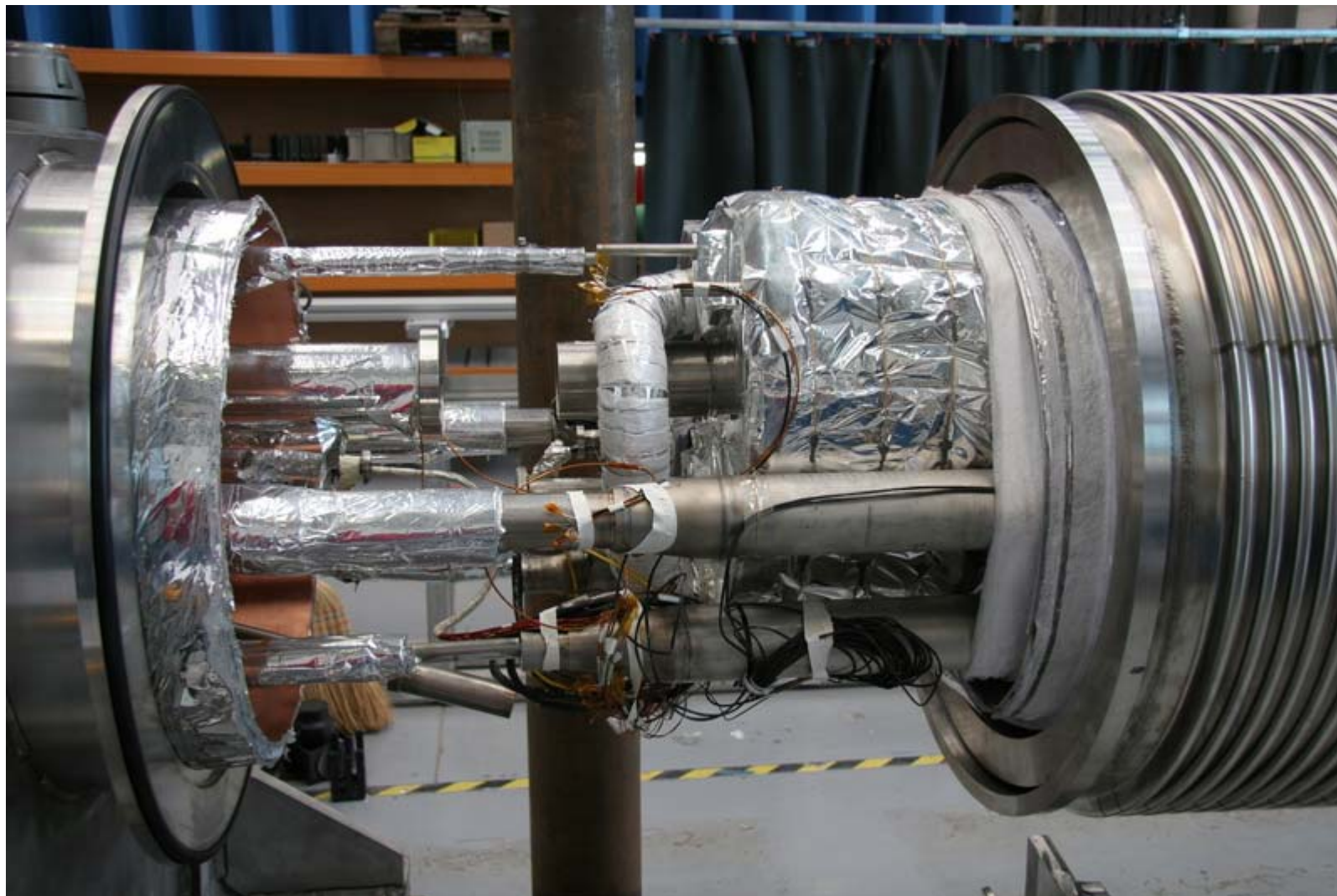



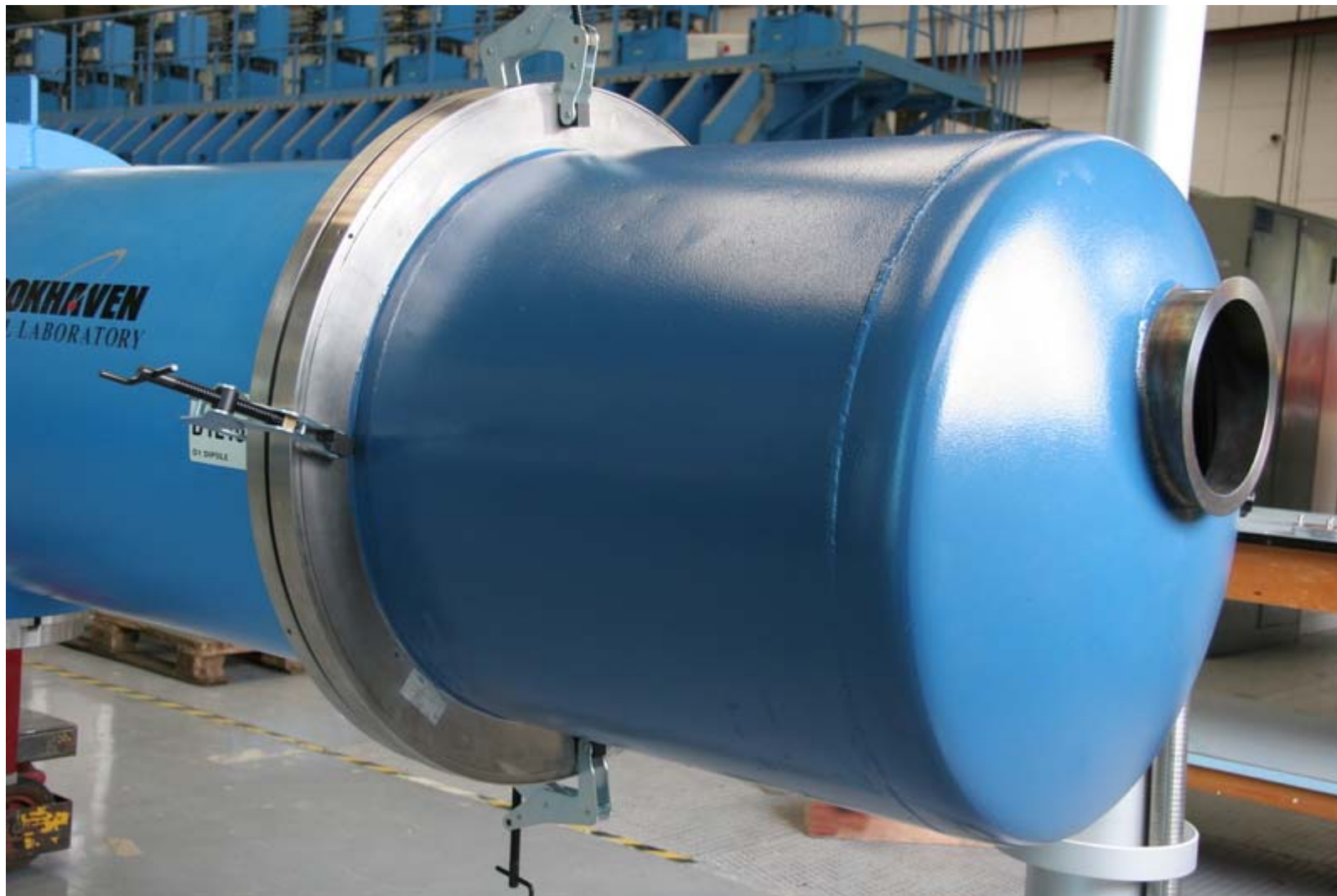



- ➔ Interconnections between quadrupoles and Q3-DFBX:
 - FNAL done a very good job of the design and delivery of all components and tooling under their responsibility.
 - Some tools have to be improved (e.g. tools for compressing bellows), and components modified (e.g. flanges, fixing holes in thermal shields).
 - CY' missing! (25 mm copper tube has to be pulled through from Q3 to Q1 before installation of the DFBX).
 - Interference between BPMS signal cables and Q2 thermal shield. Redesign necessary.
- ➔ Interconnections between DFBX-D1
 - Several components were not delivered by BNL or need to be modified.
- ➔ General
 - Polarity of magnets confirmed in the string.
 - Instrumentation and continuity from DFBX confirmed.
 - Alignment of magnets under vacuum confirmed.
 - Limited rigidity of the jacks and their supports.

LOW BETA TEST STRING - WPS 27.05.2005

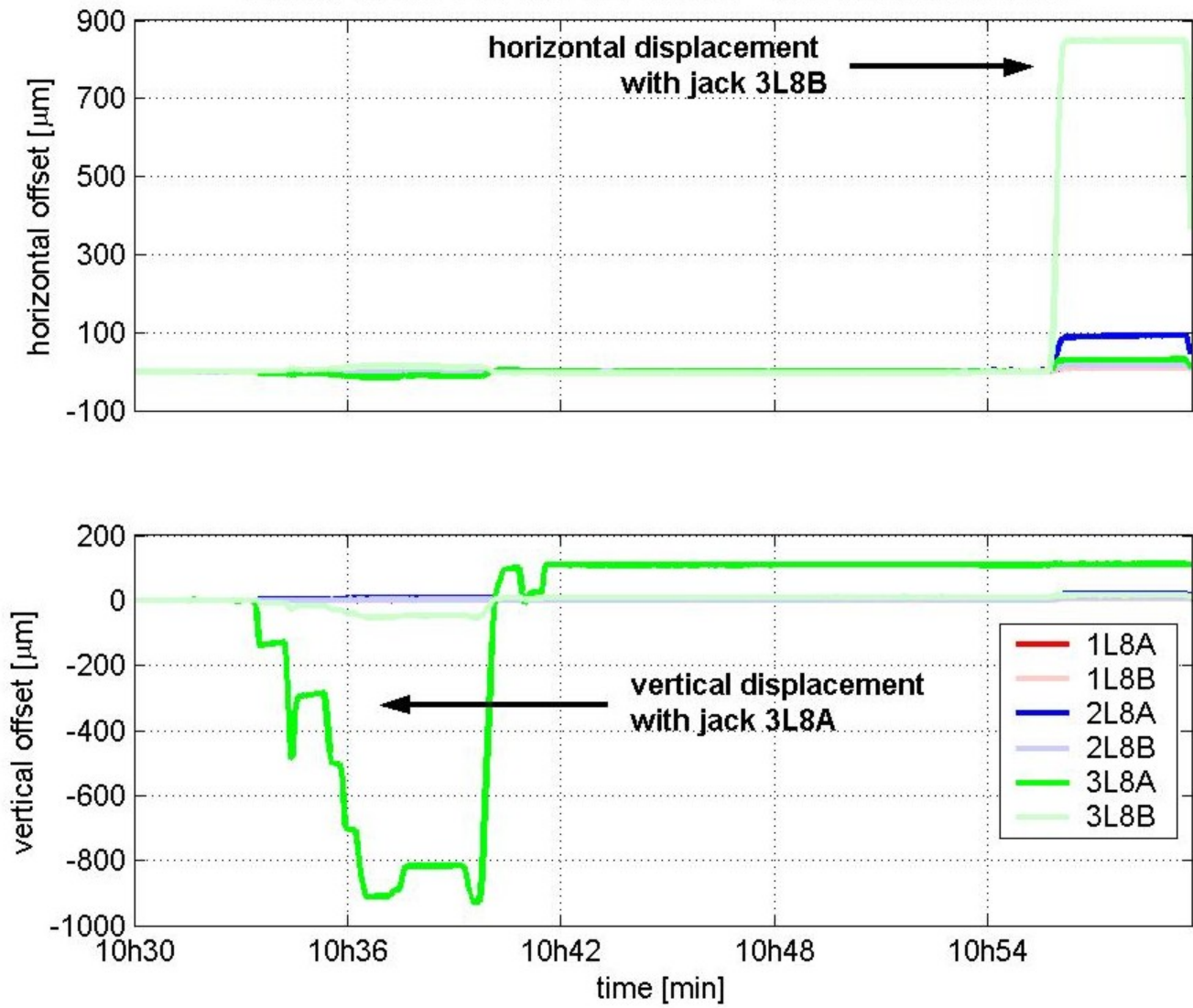

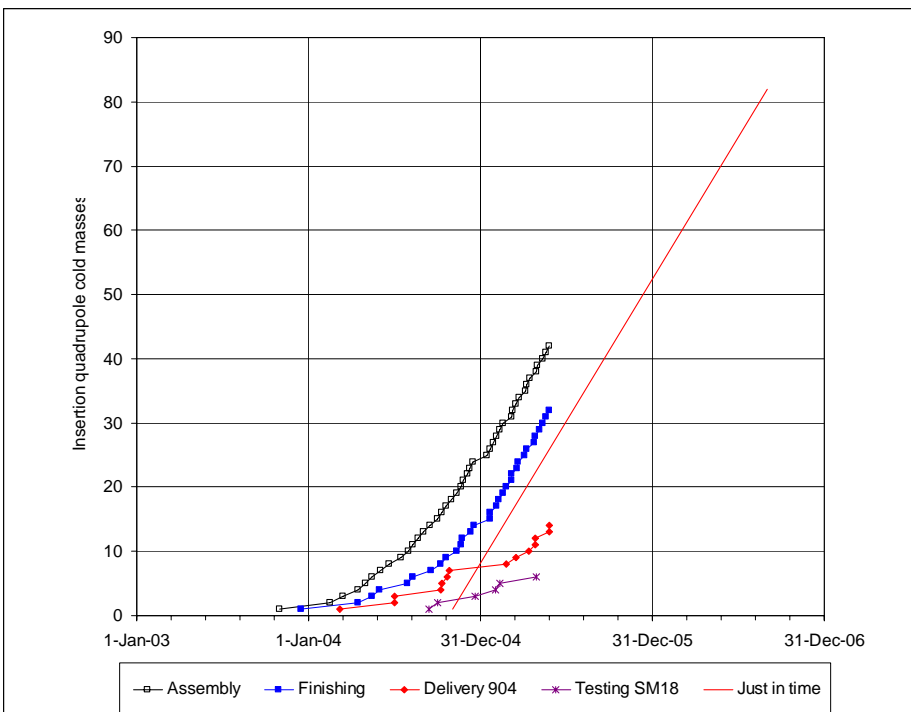

Installation Readiness of LSS in IR8

	Left							Right						
	Q10	Q9	Q8	Q7	Q6	Q5	Q4	Q4	Q5	Q6	Q7	Q8	Q9	Q10
1	LMQMD615	LMQMH616	LMQMD617	LMQMF690	LMQMM619	LMQMN620	LMQYC621							
2														
3														
4		LMQM630	LMQMC631						LMQYH635	LMQYB636		LMQMD638	LMQMH642	LMQMD641
5	LMQMD640	LMQMH603	LMQMD643											
6														
7														
8	LMQMD601	LMQMH639	LMQMD602	LMQMF604	LMQMJ605	LMQML606	LMQYJ607	LMQYI608	LMQYE609	LMQMJ610	LMQME611	LMQMD612	LMQMH613	LMQMD614

- To date only DS type quadrupoles cryostated and tested
- Cryostating:
 - Components for Q4L8 available beginning June 05.
 - Assembly rate of 4 quadrupoles per month (one MS and 3 DS) as from mid-July 05.
- Testing:
 - From beginning 2005 priority given to arc-SSS. As from June 05, one bench devoted full time for insertion quadrupoles.
 - Five insertion quadrupoles (DS type) in backlog.
 - Test rate (1 week per magnet; 2 weeks per magnet for Q4 and other first of the kind magnets).

It is expected that Q4L8 may be available for installation on 1 October 05. Q5L8 and Q6L8 will follow in intervals of one month.

- Components expected for 15 July 05.
- No manpower allocated; no space allocated.
- First of the kind activity.

It is estimated that it may be possible to complete 2-3 magnets by 15 August 05.

- MBWXS and MBXWH magnets available
 - Vacuum chamber to be installed
- Survey markings to be done
- Support and transport tools to be designed

It is estimated that the resistive magnets can be ready for installation by 15 August 05.

IR8L:		
Element	Installation date	Critical activity
MBXWS,H	18.08.05	
Q1-Q2-Q3	18.08.05	SMI2
DFBX-D1	07.10.05	
D2-Q4		Q4 completion (904-SM18)
Q5,Q6	10.10.05	→ Dec. 05 (904)
IR8R:		
MBXWS	19.08.05	
Q1-Q2-Q3	19.08.05	→ Oct. 05 (SMI2)
D1	05.12.05	
D2-Q4		
Q5,Q6	12.12.05	

- Interconnect team available (combined for arcs and LSS).
 - The team was not available for the inner triplet assembly in 181 in March 2005. A second assembly campaign for training under consideration.
- Components for Q1-Q3 available, for D2-Q4 interconnect in production.

Interconnections of low-beta triplet starting in October feasible.

→ The first DFBM for D2-Q4 available at best end of October.

- ➔ Two DFBX feedboxes delivered in Feb 05.
- ➔ Acceptance tests (electrical, leak tests, alignment) performed.
- ➔ Repair of instrumentation on DFBXG current leads completed.
- ➔ Modification and check of interfaces to D1 to be done.
- ➔ Installation of signal distribution boxes end of June 05.
- ➔ Design and fabrication of gas recovery manifold and superstructure by Sep 05.
- ➔ Next two DFBX expected end of June.



- ➔ Handling and transport:
 - One spreader beam for magnets and one for DFBX available.
 - Transfer tables for low-beta quads in production (expected Aug 05).
 - Transport wheels for DFBX in design (expected July 05).
 - Transport route for D2, Q4, Q5 and Q6 through PX24 (to be confirmed).
- ➔ Low-beta triplet placement:
 - Survey markings to be done.
 - Jack support plates to be ordered (expected August 05).
 - Standard jacks available. Motorization under test, to be installed later.
 - Alignment equipment available for one triplet; remaining equipment to be ordered in June 05.
- ➔ Shielding around IR8 to be ordered (expected in Sep/Oct. 05).

Critical activities and items:

- SMI2 (for equipment scheduled in August and Oct 05).
- Cryostating (904) and testing (SM18) (for Q4 scheduled in Oct 05.)
- DFBM (for Q4-D2 string in October 05)
- Elements of infrastructure (for Q1-Q3 installation in Aug 05)

A large number of activities and items are on the critical path.

There is a risk that installation of LSS in IR8 will be delayed due to high-tech but also due to low-tech items (should have been resolved earlier).

Hardware commissioning of subsector Q1-Q2-Q3-DFBX-D1 possible by end of 2005; not realistic for Q4-D2.