

EFFECT OF THE MAGNETIC HYSTERESIS ON THE LHC CROSSING ANGLES AND SEPARATION BUMPS

N.Sammut, W.Venturini Delsolaro,
S.White.

INTRODUCTION

Three types of dipole magnet are used to generate the crossing angle and separation:

⇒ MCBC and MCBY situated after the triplets where the two beams are separated.

⇒ MCBX situated where the beams share the same vacuum chamber.

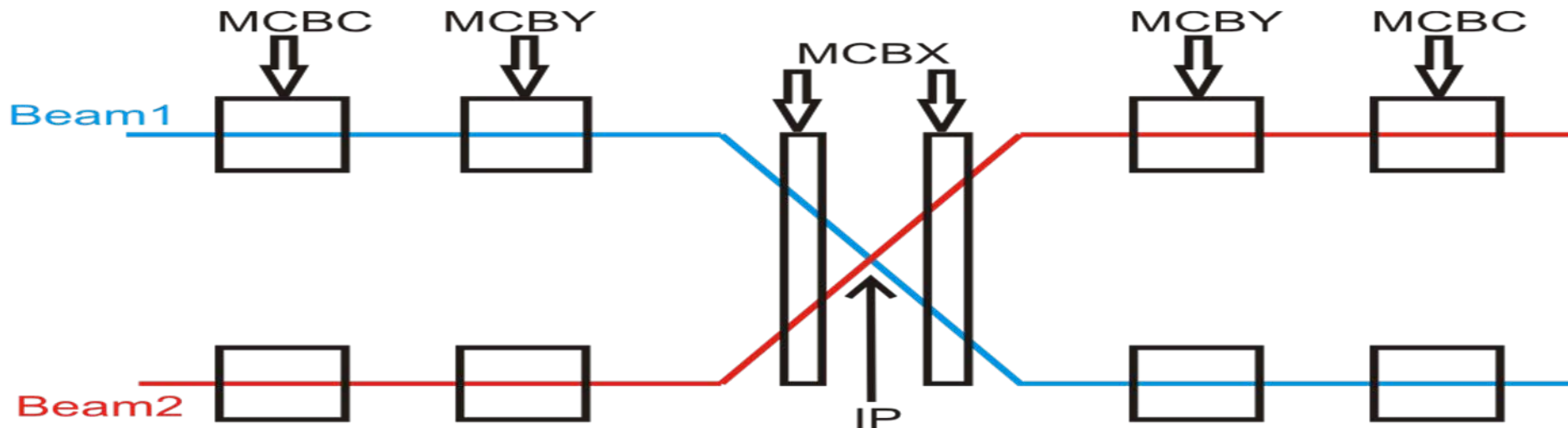

MEASUREMENTS AND MODEL

The Transfer functions were modeled using FiDeL based on dedicated warm and cold measurements in Block 4.

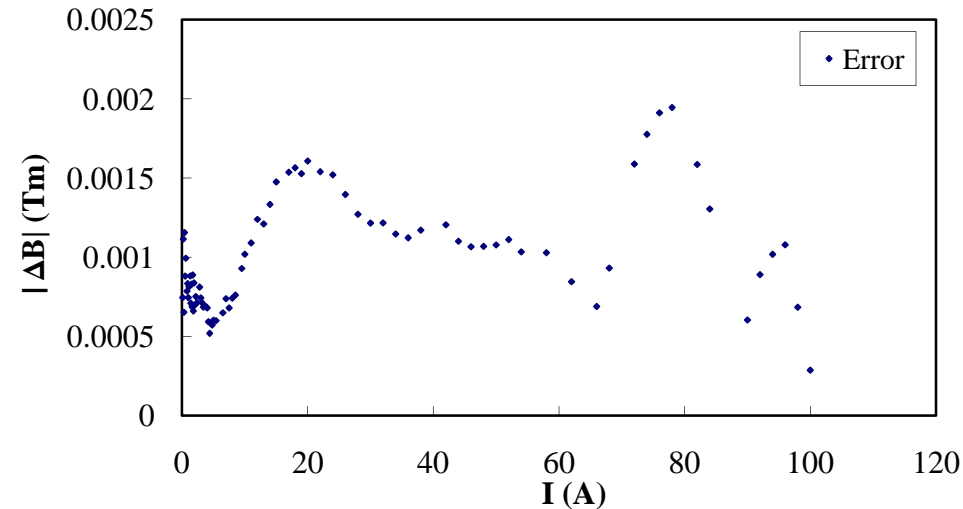
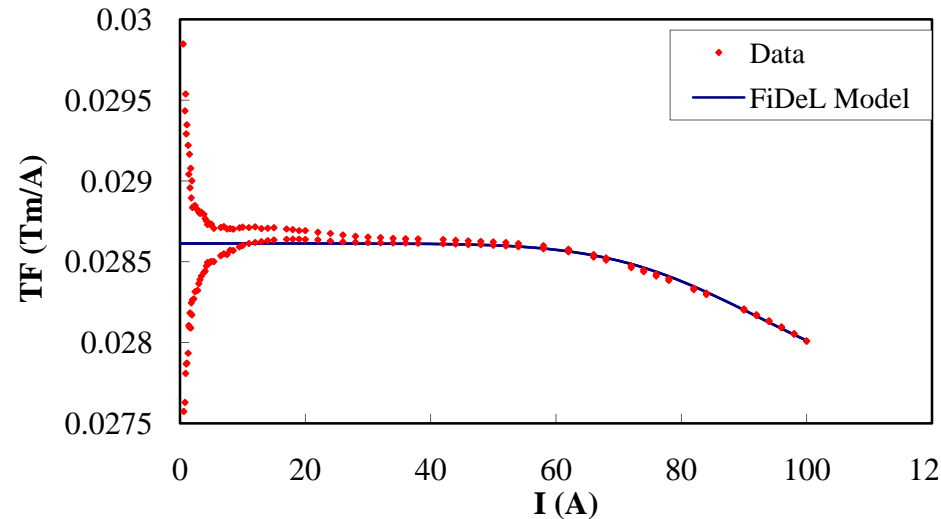

Example of the MCBC : note that the hysteresis was not modeled in this case. It is then necessary to evaluate the relevance of this effect.

SIMULATIONS

Based on the measurements a simple model was built in order to give an upper estimate of this effect.

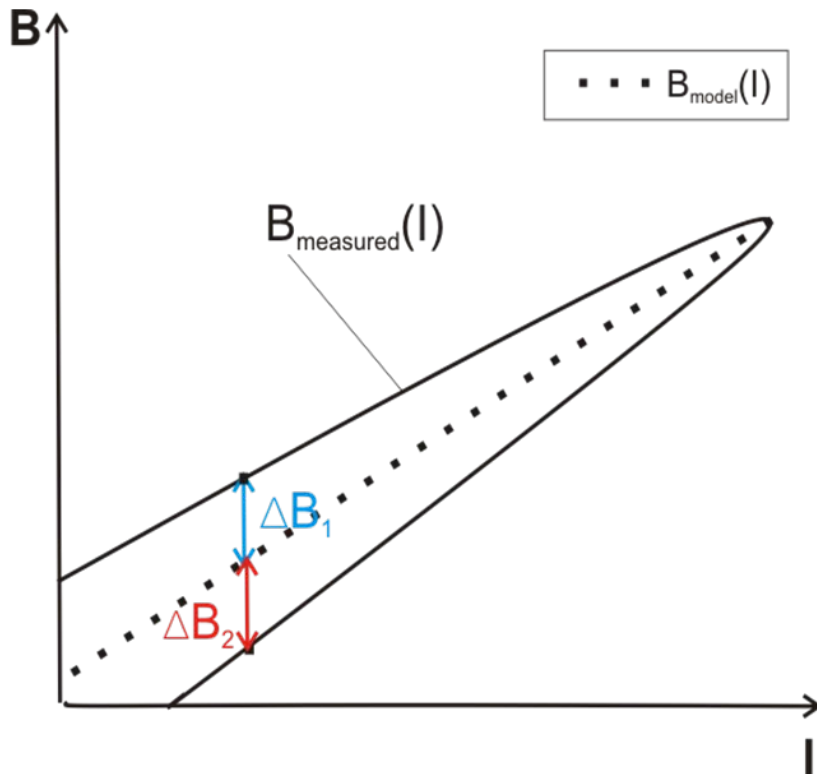

$$B_{\text{tot}} = B_{\text{model}} \pm \text{MAX}(\Delta B_1, \Delta B_2)$$

Using this simple model and generating random signs for the ΔB it is easy to implement the hysteresis errors into Mad-X to get a hand on the consequences for the orbit.

MCBC AND MCBY

All the simulations were performed using the optics V6.500.

	Errors due to the Hysteresis cycle in the MCBC and MCBY			
	Vertical Plane		Horizontal Plane	
	Position (Beam σ)	Angle (μrad)	Position (Beam σ)	Angle (μrad)
IP1	0.04	1.5	0.06	1.3
IP2	0.04	0.4	0.05	0.3
IP5	0.04	1.3	0.05	1.5
IP8	0.05	0.3	0.03	0.4

The maximum errors we get are $\sim 5\%$ of a beam σ in position and $\sim 1.5 \mu\text{rad}$ in angle. Those values are very small and within the errors expected from the beam-beam effects.

MCBX

FiDeL modeling errors in the vertical (left) and horizontal (right) components of different sets of MCBX magnets.

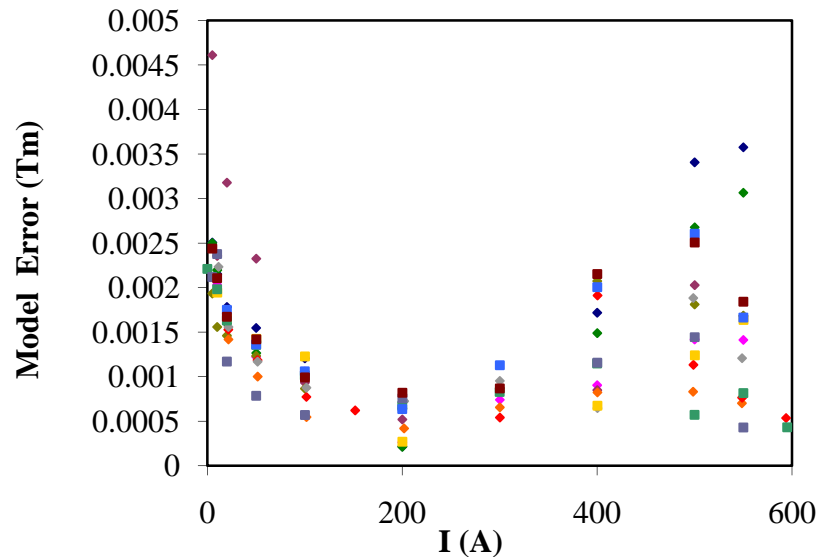
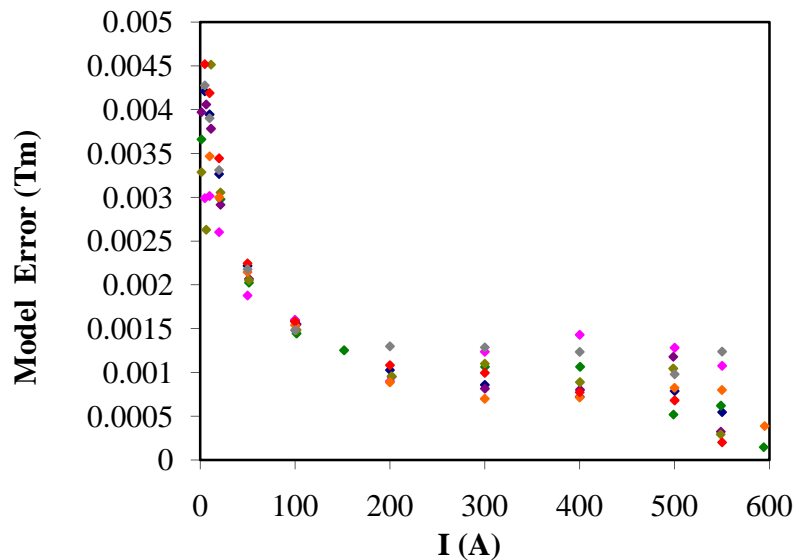

If we now look at the errors in the MCBX we can see that the order of magnitude is ~ 5 times larger than the one in the MCBC/Y. \Rightarrow The orbit errors are also larger : approximately 1σ in position and 10% in angle in the worst case ($15\mu\text{rad}$ at IP5) .

ORBIT WITH MCBX ERRORS

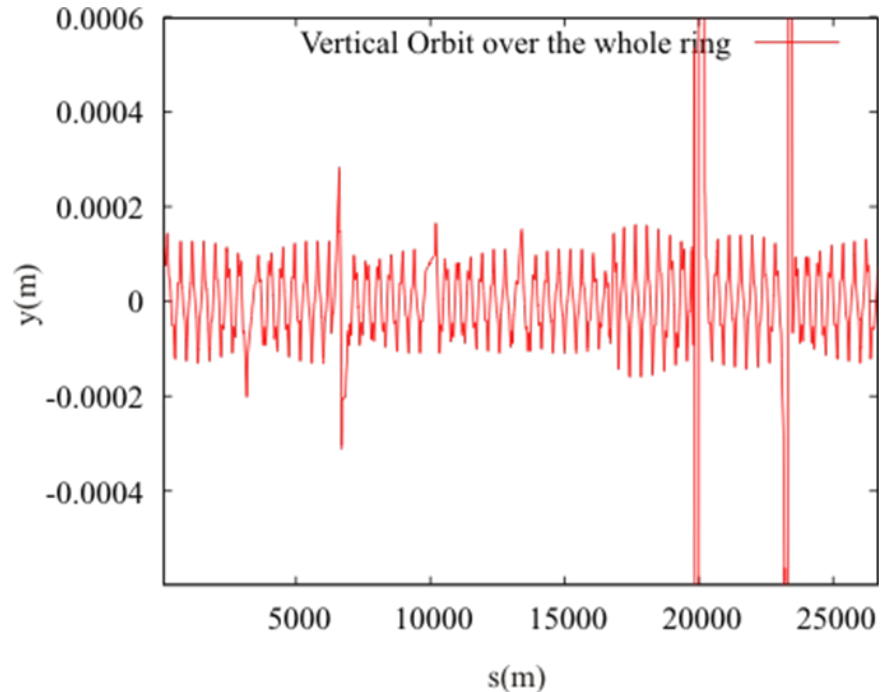
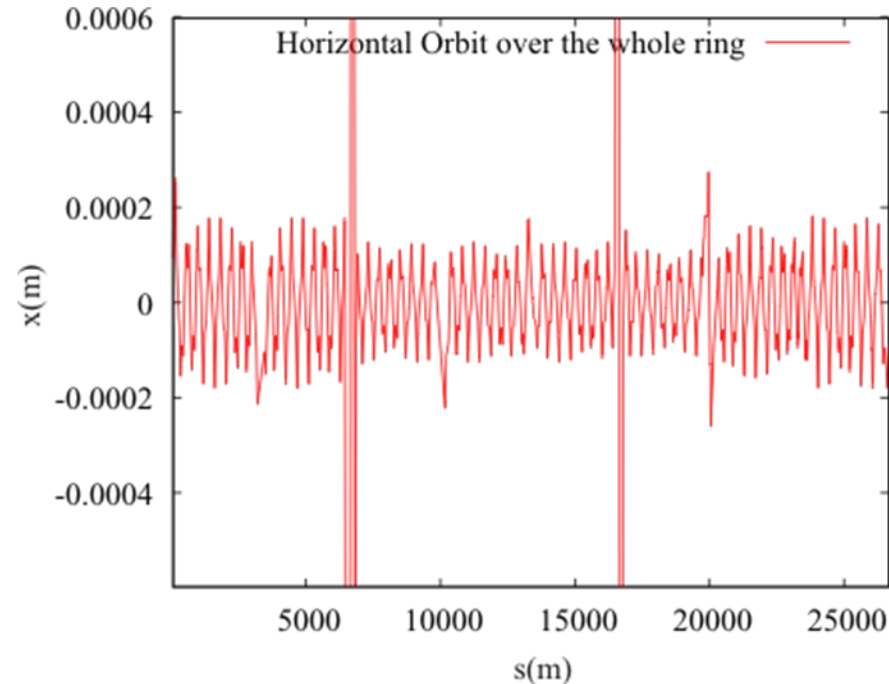

By adding the MCBX errors we generate a residual orbit with ~ 0.07 mm in x and ~ 0.06 mm in y in this case(rms outside crossing angles).

ESTIMATES ON THE MODEL REQUIREMENTS

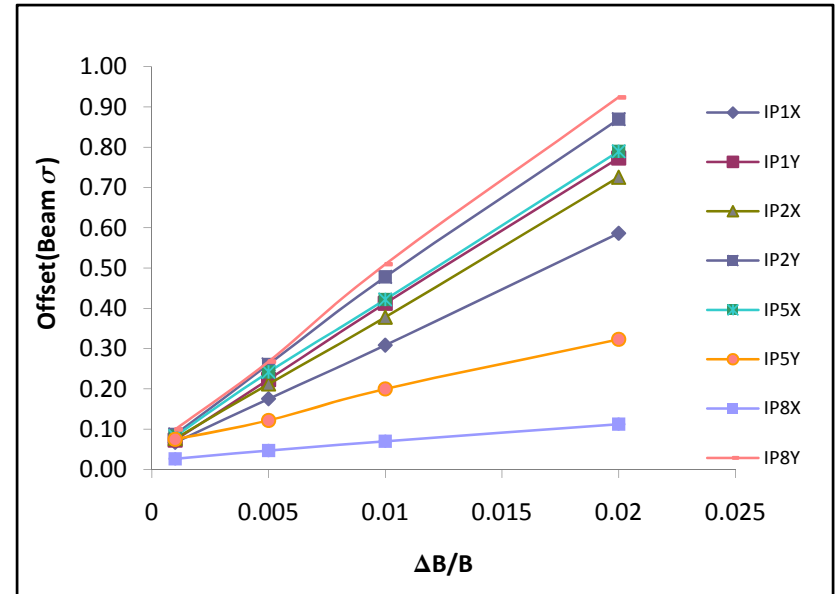
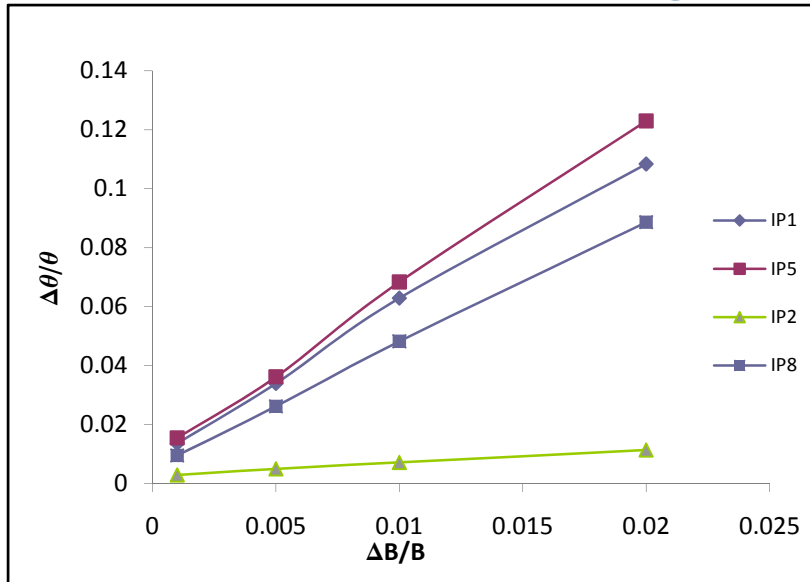

To have an idea on how precise the model should be we can look at how the orbit evolves with the field errors. Those plots show the effect of the field error on the crossing angle (left) and position (right) => **a model with a precision of $\sim 0.2\%$ should be enough** to get errors of the same order as the ones from the beam-beam effect.

SUMMARY

- MCBC : Effect of the hysteresis very small and within the beam-beam effect.
 - MCBX : Non negligible errors at the IPs.
- ⇒ In order to reduce those errors we need to precisely model the hysteresis cycle which strongly depends on the history of the magnet.
- ⇒ Therefore we have to define and provide the **complete powering cycle** (from injection to collisions) during LHC operation for those critical magnets in order to build an efficient model.