

# HIGHLIGHTS FROM THE ILCDR08 WORKSHOP (CORNELL, 8-11 JULY 2008)

report by S. Calatroni and G. Rumolo, in CLIC Meeting 25.07.2008

- Goals of the workshop:
    - 4<sup>th</sup> of the ILCDR series, on R&D projects necessary for the design of the ILC Damping Rings:
      - Low Emittance Tuning
      - Electron cloud
    - Kickoff meeting for CsrTA:
      - Define the use of CsrTA as test facility for specific subjects related to the above topics
  - 4 Electron Cloud Working Sessions:
    - Observations and measurements
    - Status of simulation tools
    - Mitigation techniques
    - Experimental planning
- } Giovanni
- } Sergio



- Goals for this workshop are two-fold:
  - Continue the reorganization of the ILC Damping Rings Effort for the ILC Technical Design Phase
    - Re-scoped plan
  - Bring together experts on low emittance tuning and electron cloud effects to provide guidance and suggestions for the CesrTA program
    - 2 years of flexible experimental operations - need to maximize the impact of the program
    - Explore synergies with other electron cloud and low emittance tuning groups
    - Explore options for collaboration in the new budget environment
    - Get input to ensure that we carry out the most important experiments to provide a viable damping ring design when it is time to move forward with the construction of a linear collider



## CesrTA Program II

- Down to reconfigure CESR  $\Rightarrow$  CesrTA has just started
- R&D Targets:
  - Now through mid-2009
    - Complete low emittance machine reconfiguration and upgrades
    - Deploy and commission instrumentation needed for low emittance program
    - Study EC growth studies in wigglers, dipoles, quadrupoles and drift regions in CESR
    - Initial EC mitigation studies
  - Mid-2009 through April 1, 2010
    - Work towards progressively lower emittance operation
    - Complete EC mitigation studies
    - EC beam dynamics studies at the lowest achievable emittances
    - Focus shifts much more heavily to experiment versus machine modifications



# CESR Reconfiguration

3841206-001

## L3 Straight

- Instrument large bore quadrupoles and adjacent drifts
- Install of PEP-II experimental hardware (including chicane) in early 2009
- Provide location for installation of test chambers

## Arcs where wigglers removed

- Instrument dipoles and adjacent drifts
- Provide locations for installation of test chambers

## CHES line upgrades for x-ray beam size monitor

- D-line this summer
- C-line next year

## L0 Straight

- All wigglers in zero dispersion regions for low emittance
- Instrumented wiggler straight and adjacent sections

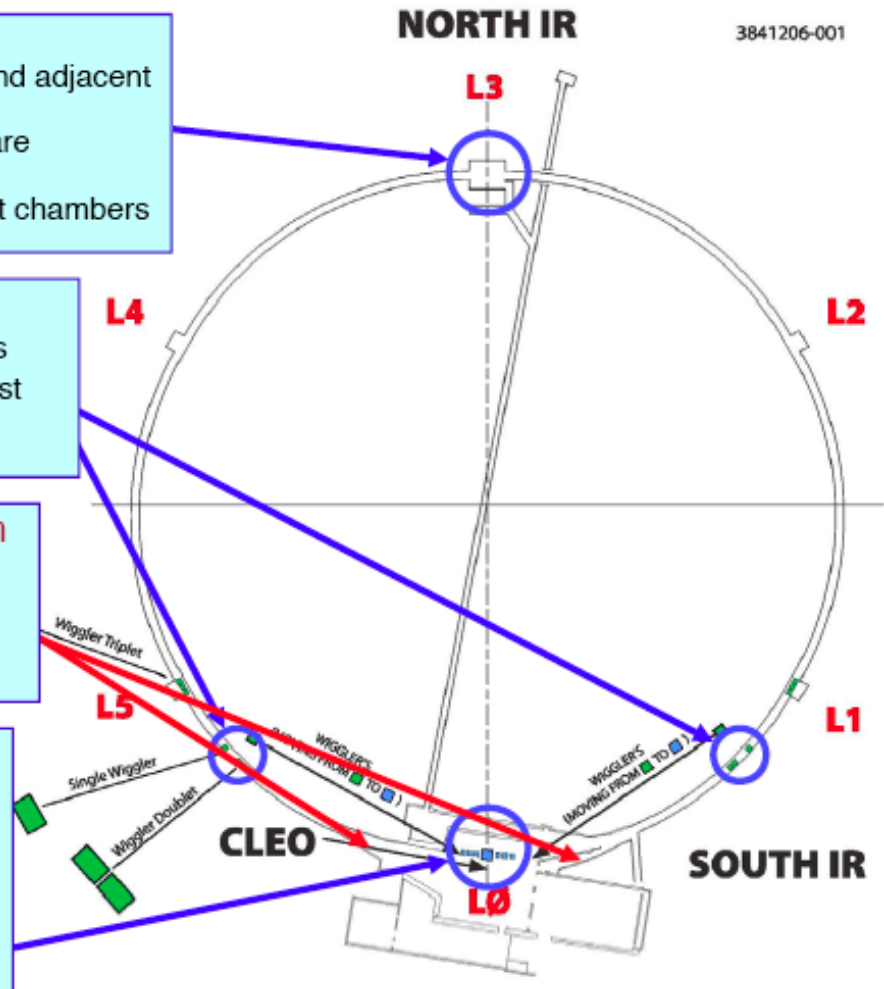

From: M. Palmer & D. Rubin, *CesrTA Introduction*

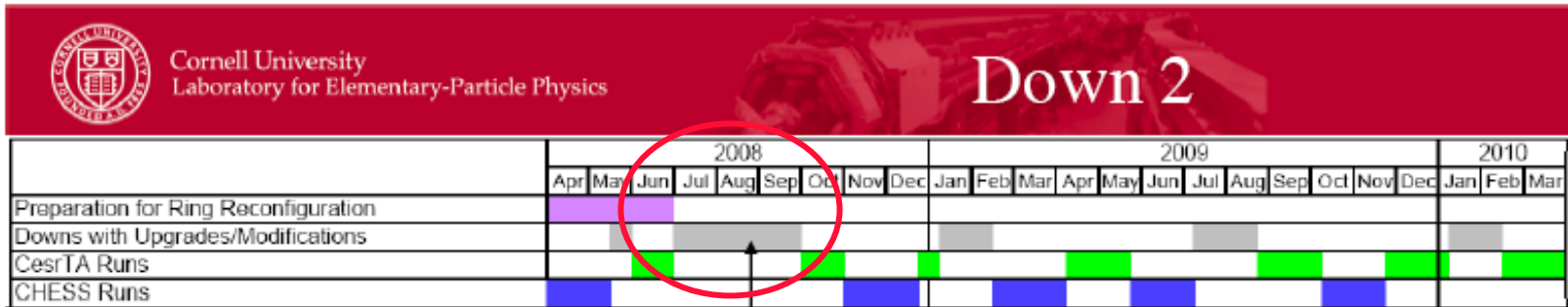

- Reconfigure CESR for ultra-low emittance
- Install positron xBSM optics line
- Start deployment of new BPM system
- Upgrade survey network and alignment hardware
- Install instrumented vacuum section in L0 (CLEO IP)
- Remove wigglers from arcs and re-deploy in L0
- Deploy first instrumented wigglers in L0 (2?)
- Install instrumented vacuum system in L3 (CUSB IP)
- Deploy L3 diagnostic chicane?
- Deploy vacuum diagnostics with wiggler replacement chambers in CESR arcs
- Complete upgrade of transverse feedback system for 4 ns bunch spacings

A quick glance to the CesrTA target parameters...

<i>Parameter</i>	<i>Value</i>
Energy	1.9 - 5.3 GeV
No. wigglers	12
$B_{\max}$	2.1 T
$\varepsilon_x$ (geometric)	2.25 nm
$\varepsilon_y$ (geometric)	20 pm (~40 nm normalized)
$Q_x$	0.59
$Q_y$	0.63
$Q_z$	0.070 - 0.098
$\sigma_z$	6.8 - 8.9 mm
$\Delta E/E$	$8.1 - 8.6 \times 10^{-4}$
Rf voltage	7.6 MV
$\tau_{x,y}$	~ 60 ms
$\alpha_p$	$6.2 \times 10^{-4}$
$N_b$	$1 - 2 \times 10^{10}$
Bunch spacing	Multiples of 4 ns and 14 ns

- Two years of CsrTA experimental program will be mainly devoted to:
  - **Study of e-cloud formation and instability**
  - Development of low emittance tuning techniques
  - Development of x-ray beam size monitor for ultra-low emittance beams
- **Additional possible studies**
  - Studies of emittance dilution
  - Ion effects
  - 2D x-ray beam size camera upgrade
  - Tests of ILC prototype hardware
  - Further emittance reduction and further refinement of tuning methodology

- **Electron cloud studies** that can be carried out at CsrTA:
  - **Benchmark** of modelling tools against experiments (code validation)
  - Verification of **mitigation techniques** (for ex. coating behavior wrt synchrotron radiation)
  - Development of **diagnostics tools**
- However
  - **Parameter range** is different from CLIC-DRs in some respects (larger bunch spacing → lower line density, lower energy, larger emittances)
  - Similar scaled bunch parameters → **Emittance growth** studies (due to e-cloud and/or space charge) maybe useful



---

# EC Working Group:

## Measurement of Cloud and Effects on Beam

---

- **Direct electron cloud observation:**
  - Measurements with the **RFA** (KEKB-LER, CEsrTA)
  - **Microwave** diagnostics (CERN-SPS, LBNL-PEPII)
- **Indirect electron cloud observation** (through the effects on the beam)
  - **Tune shift** along the batch (CesrTA, KEKB)
  - **Coherent:**
    - Single bunch instabilities (KEKB)
    - Coupled bunch instabilities (CesrTA ?)
  - **Incoherent:**
    - Emittance growth (KEKB)

# Measurement\_Kanazawa\_1

- RFA type electron detectors with Faraday cup or MCP or multi-strip anode are installed in KEKB LER.

## Electron Monitors (1)

Retarding field analyzer type electron monitors are set at pump ports of KEKB LER.

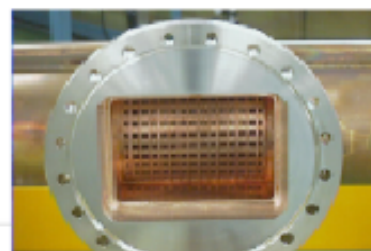

Pump port of KEKB LER

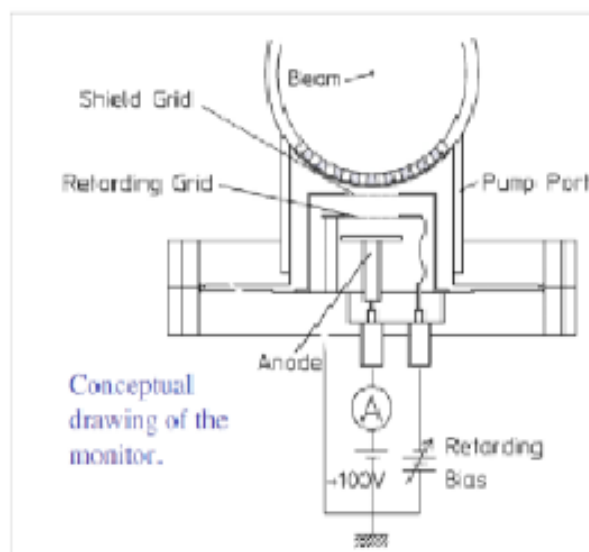

Electron Monitor (Modified Type)

# Measurement\_Ka

- Most electrons that enter below 20 eV.

## Effect of coatings

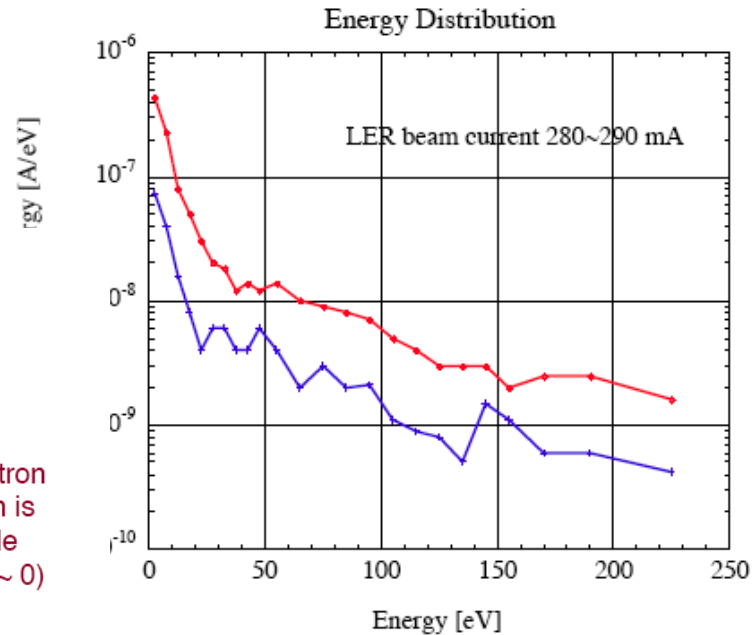
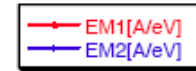
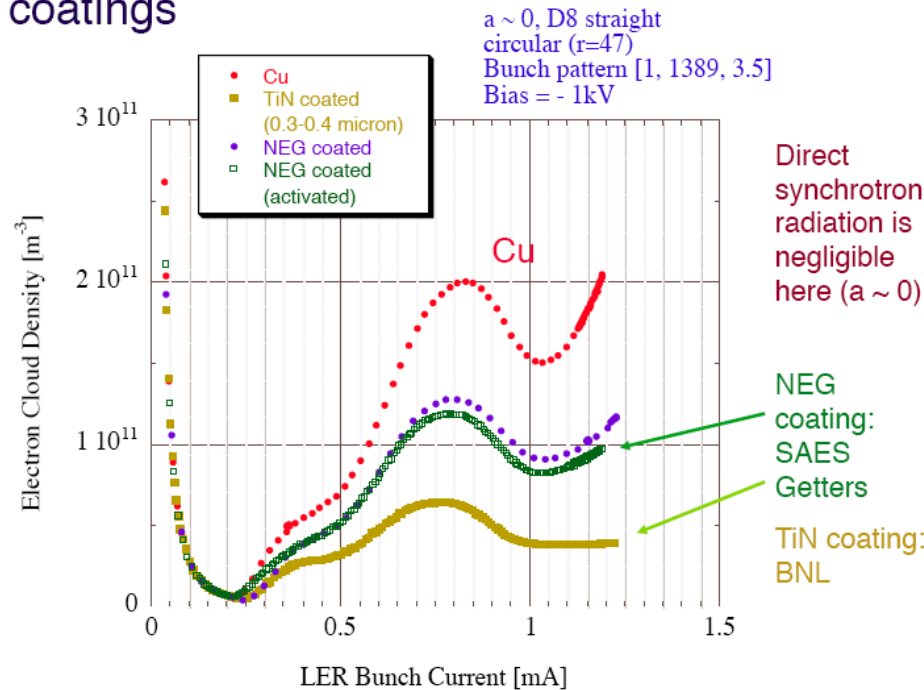

ating.

electrons that hit the  
 electron cloud near the  
 mated.

# Cornell Thin RFA

From: S. Greenwald, *RFA Development and Experimental Measurements at Csr-TA*

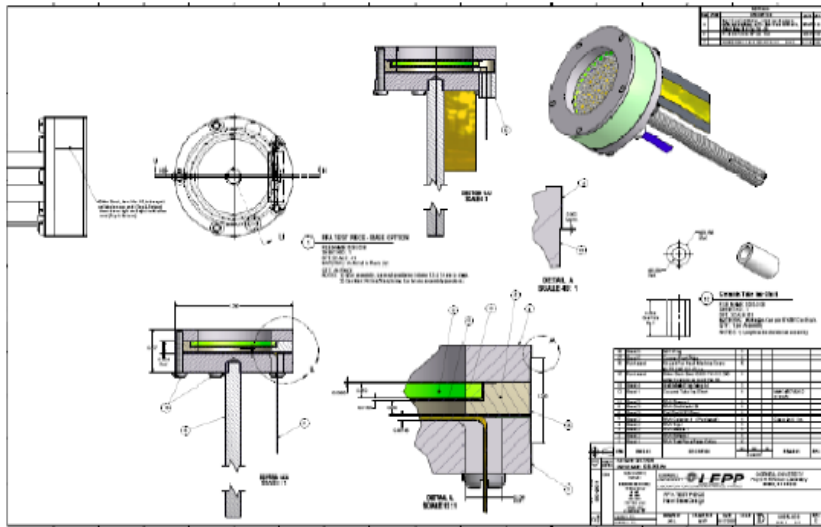

## L3 BEAM PIPE INCLUDING THE RFAS

### ■ First results

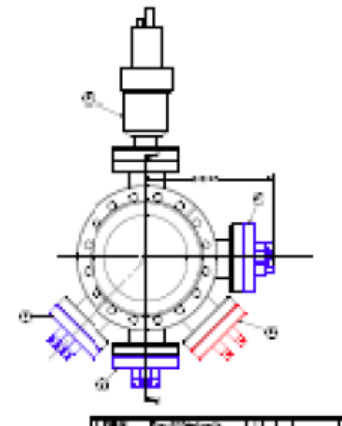
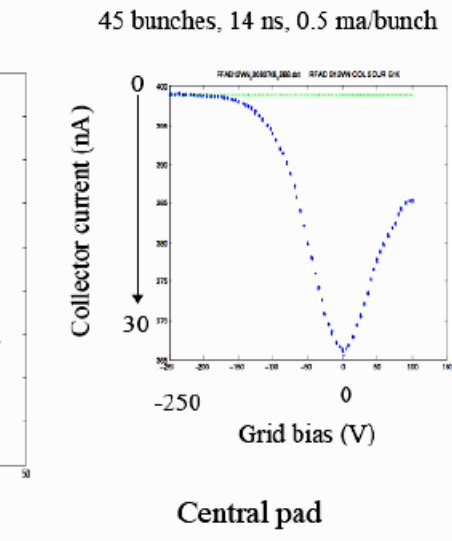
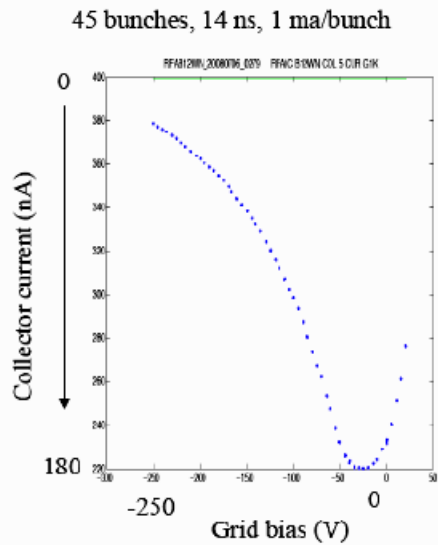

# Measurement\_Santis\_1

- First data:
  - Positron and electron beam
  - Direction of the beam.
  - Dependence on gap length and beam/bunch current
  - Effects of vacuum chamber shapes
  - Dependence on beam energy
  - Cyclotron resonance

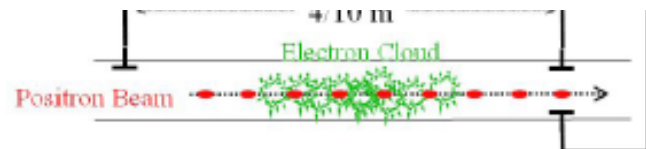
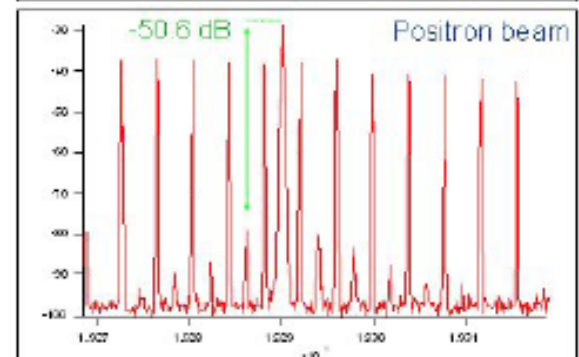
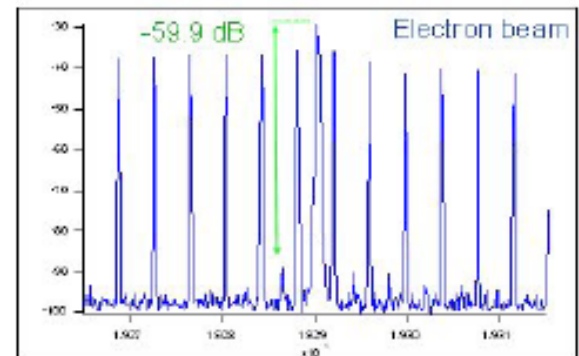

CesrTA dipole/ex-wiggler

# Measurement

- TE wave transmission measurement to measure density at

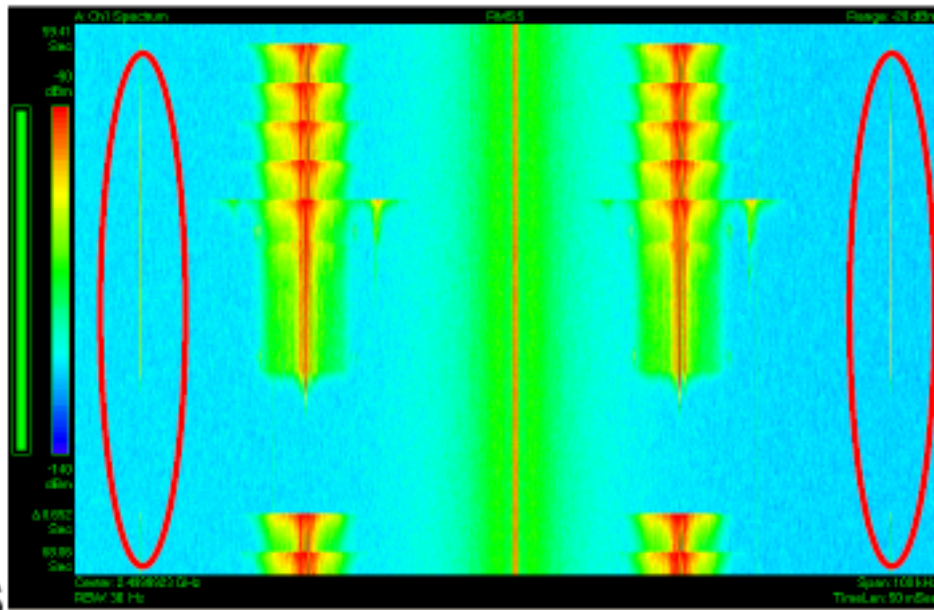

## Test set-up

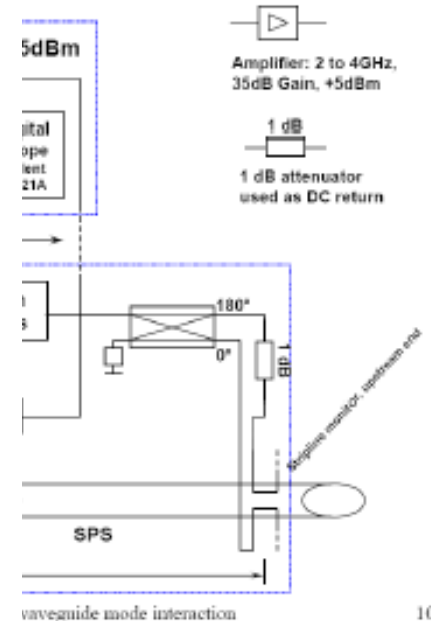

Principle idea:  
 "When electromagnetic waves pass through a not too small attenuator, they experience a phase shift and a small attenuation."

- Setup simulation measurement

Antenna1

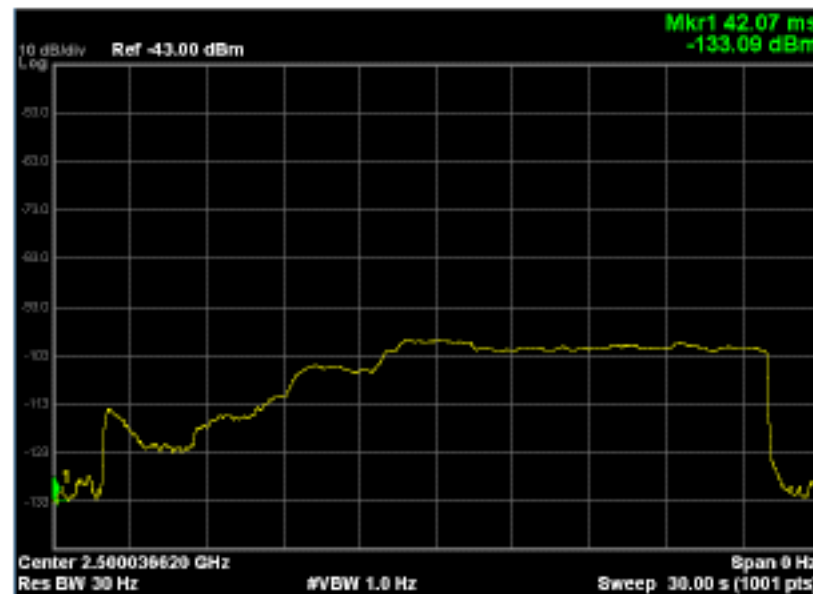

Antenna3



Intensity of the modulation sideband vs time in logarithmic scale

- **Emittance**

- Beam pattern
- Close
- 12, 16 the syn by the
- No em

- No e-cloud (5/14) (98ns spacing)
- With e-cloud (5/27) (16ns spacing)

## H. Tune Scan (at $\nu_y=0.6$ )

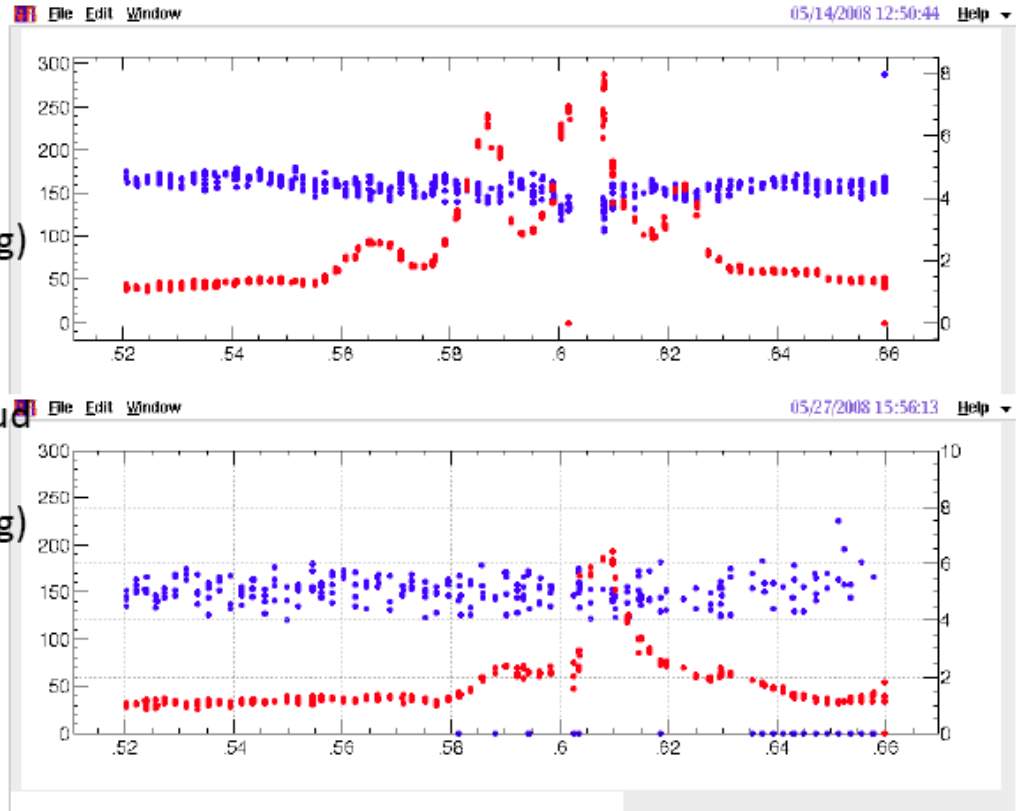

- **Emittance**

- No em synch
- Tune s (bunch instability) observed



# Effects on Beam\_Flanagan\_1

- Vertical synchro-betatron sidebands found at KEKB LER, which are a source of beam blow-up.

- Signal has a component supporting instability

- Measurements are critical

- This should be avoided

==> T

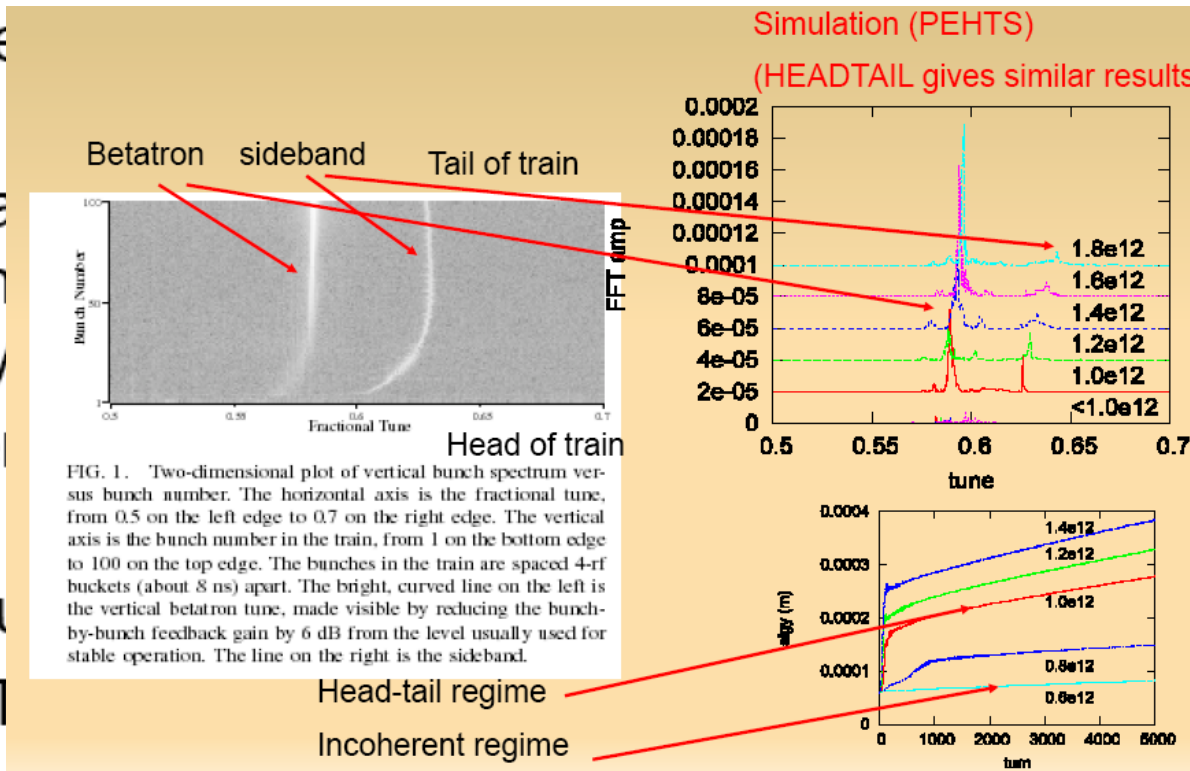
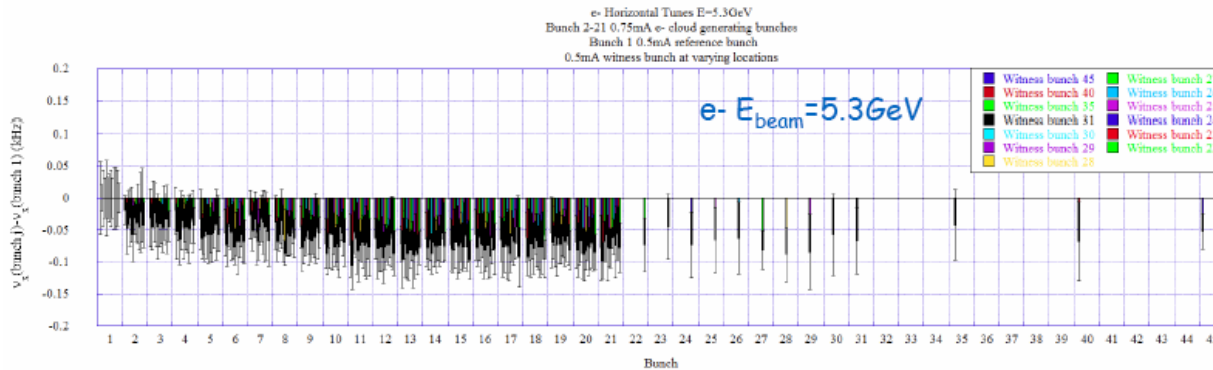
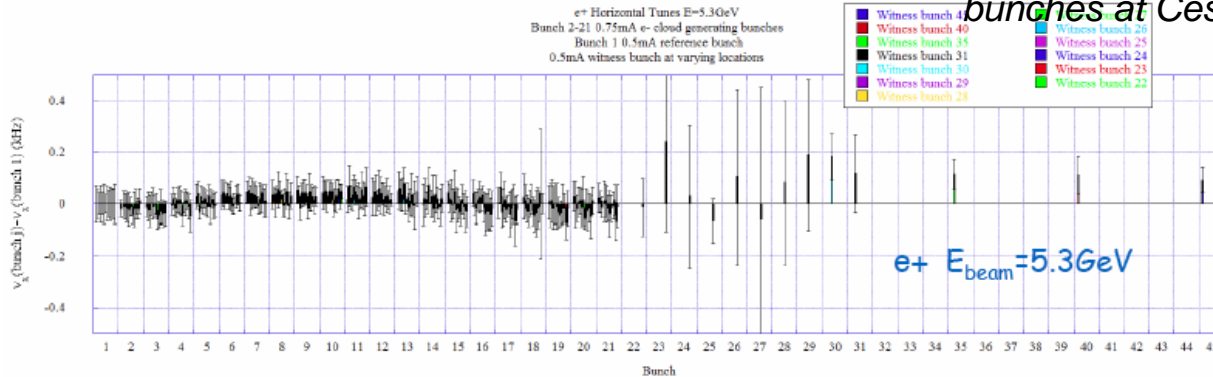

FIG. 1. Two-dimensional plot of vertical bunch spectrum versus bunch number. The horizontal axis is the fractional tune, from 0.5 on the left edge to 0.7 on the right edge. The vertical axis is the bunch number in the train, from 1 on the bottom edge to 100 on the top edge. The bunches in the train are spaced 4-rf buckets (about 8 ns) apart. The bright, curved line on the left is the vertical betatron tune, made visible by reducing the bunch-by-bunch feedback gain by 6 dB from the level usually used for stable operation. The line on the right is the sideband.

E=5.3GeV 20 bunch generating train@0.75mA/bunch, reference & witness bunch@0.5mA. x From: R. Holtzapfel, *Studies with witness bunches at CesrTA*



ital

& witness bunch@0.5mA:  $v_y$

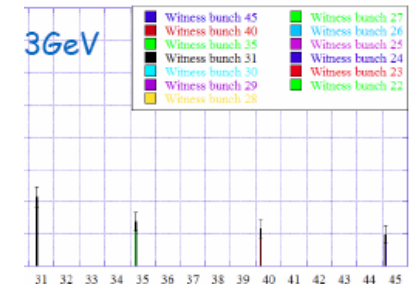

- e+  $\Delta v_x \sim 0\text{kHz}$  along generating train. Large scatter in the tune measurement for the witness bunches.
- e-  $\Delta v_y \sim -0.05\text{kHz}$  along generating train

TO CHARACTERIZE IT  
various witness bu

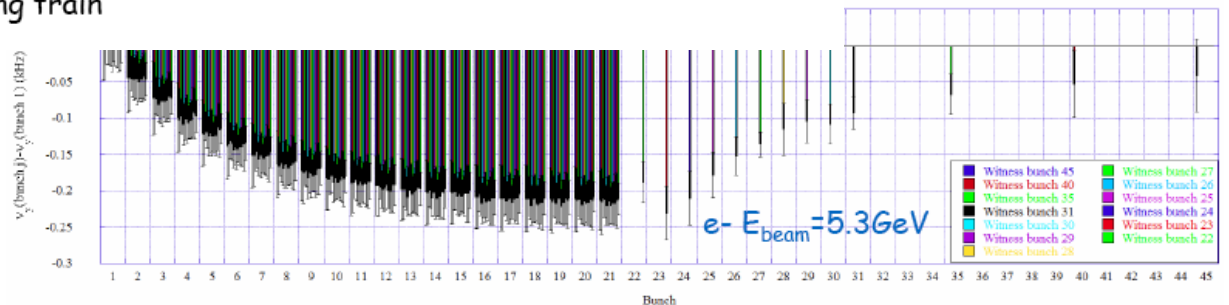

- e+  $\Delta v_y \sim 0.65\text{kHz}$  along generating train. The decay time of the vertical tune is  $\sim 150\text{ns}$ . Slope of the tune shift changes along the generating train. Tune measurement is repeatable!
- e-  $\Delta v_y \sim -0.22\text{kHz}$  along generating train which levels out  $\sim$  bunch 16. The decay time of the vertical tune  $\sim 200\text{ns}$ . **Note:** In both cases the tune shift does not go to zero by bunch 45.

---

**EC Working Group:**  
**Ecloud Simulations Group: Summary**

---

ECLLOUD, POSINST, CLOUDLAND

## Talks in simulation session

- G. Dugan: "Simulations at Cornell for CesrTA"
- J. Calvey: "Simulations for RFA studies at CesrTA"
- J. Crittenden: "Simulations for witness bunch studies at CesrTA"
- T. Demma: "Build-up of electron cloud in DAΦNE in the presence of a solenoid field"
- C. Celata: "Electron cloud cyclotron resonances for short bunches in magnetic fields"
- K. Ohmi: "Study of electron cloud instabilities in CesrTA and KEKB"

POSINST

PEHTS, HEADTAIL

ECLLOUD



- Match within factor of 2

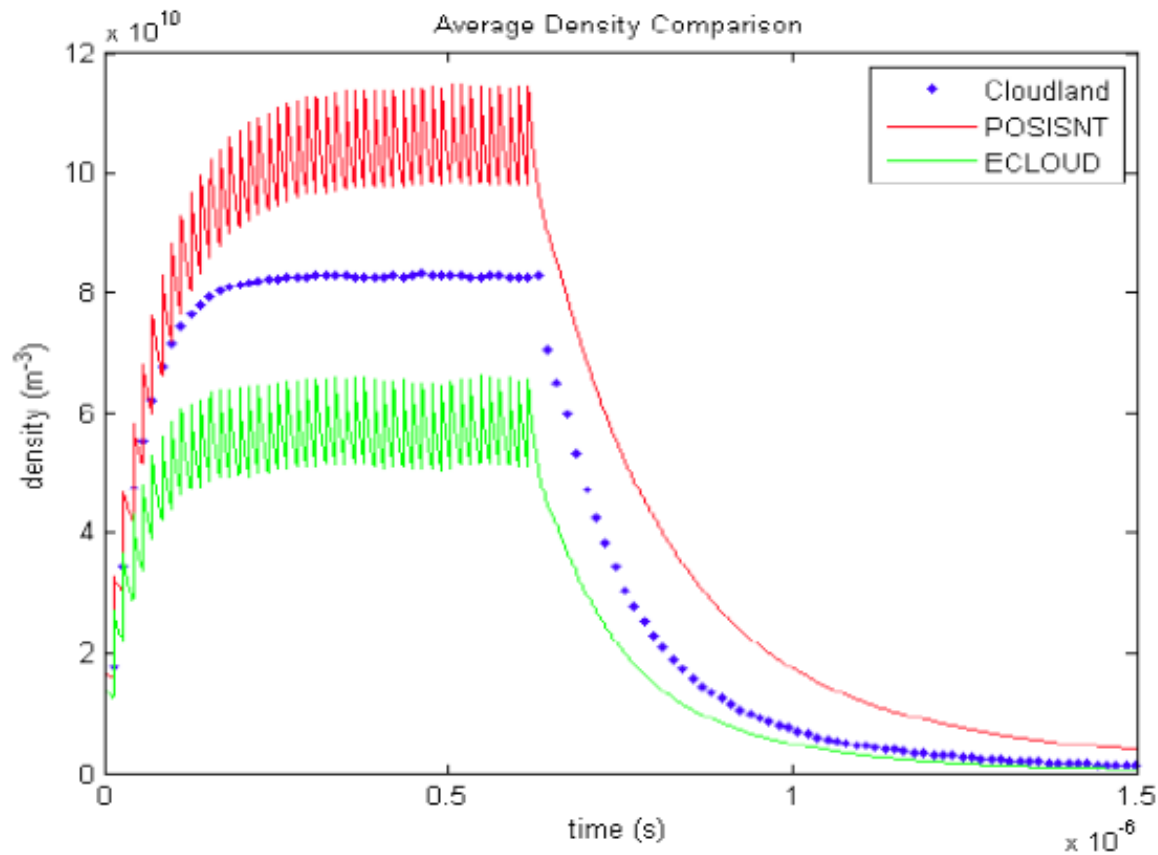



## SEY Models

- Significantly variation between simulation programs
  - Whether rediffused electrons are included
  - How “true secondaries” and reflected electrons are weighted
- Probably main reason for discrepancies

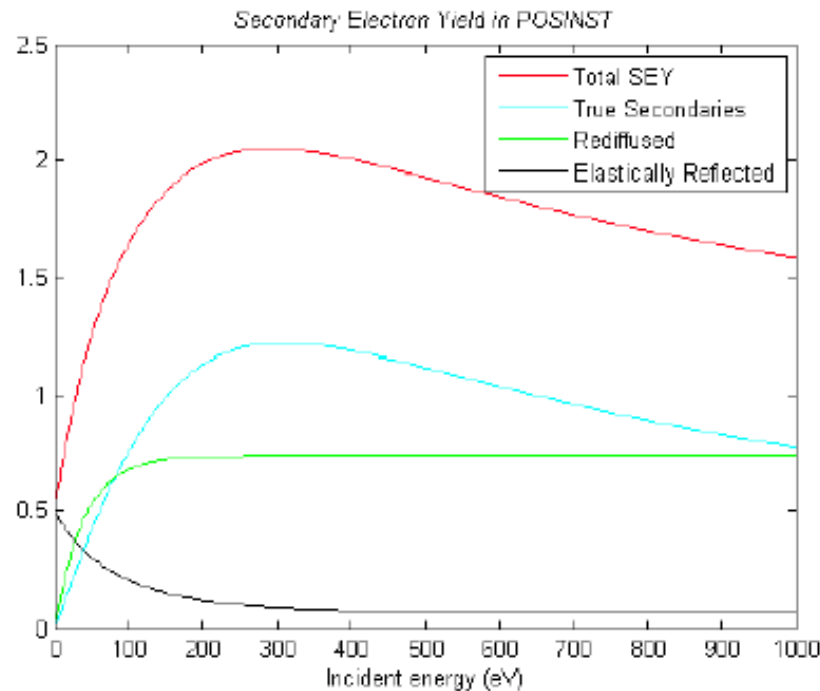

From: C. Celata, *Cyclotron resonances in magnetic fields*

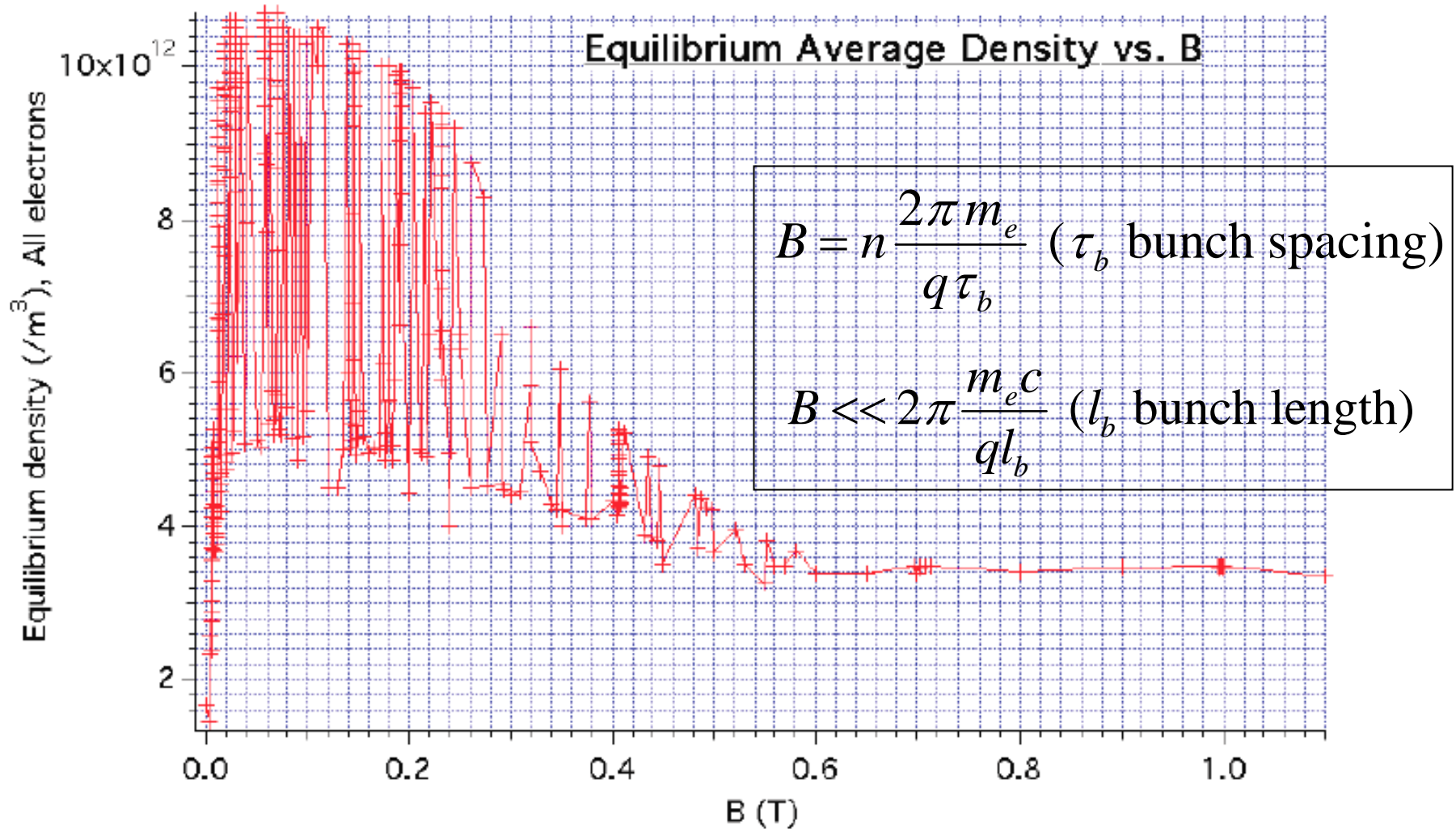

From: C. Celata, *Cyclotron resonances in magnetic fields*

**n=12**

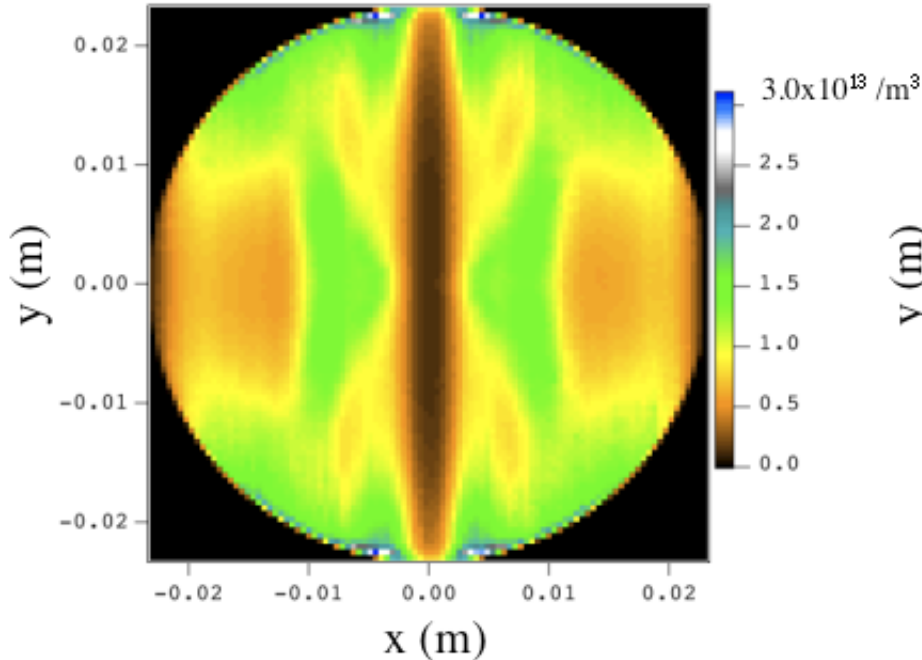

**n=137.8**

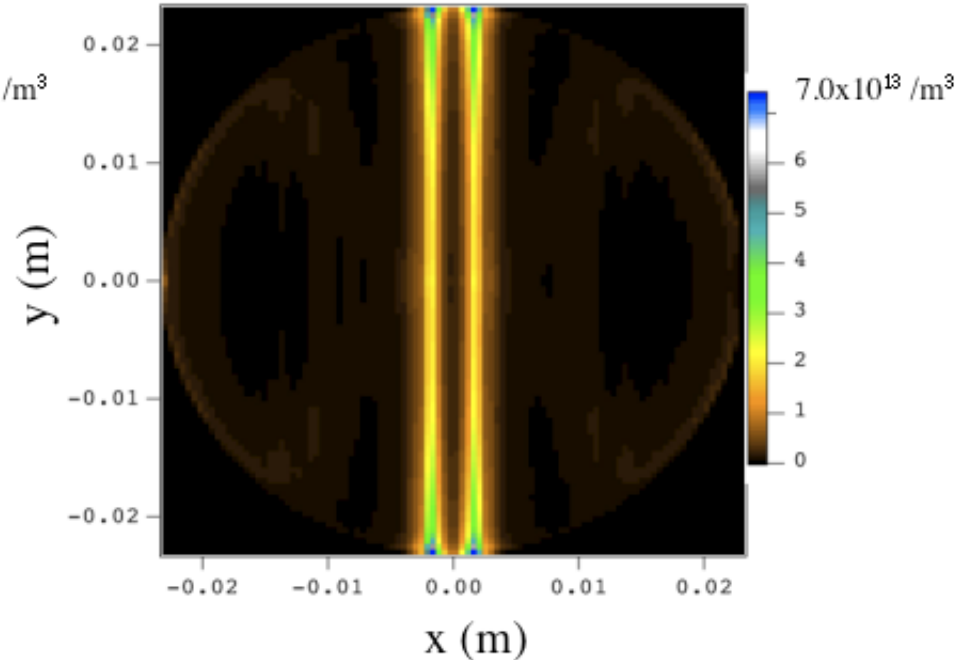

*The high-field (no resonance) case shows the characteristic “stripes” pattern seen in many experiments. At resonance the electrons are much more widely distributed in x.*



## 3D Wiggler Calculations are Essential but Challenging

### *Need to simulate 3D effects:*

- ExB drift  $\Rightarrow$   
 $e^-$  s  $\Rightarrow$  different z (and B)  $\Rightarrow$  go in (and out) of resonance.  
Resonance may affect more  $e^-$ s, but each gains less energy  
What is the sign of the effect?
- Use **correct 3D field**:  
 $B_x$  and  $B_z$ , and variation in  $B_y$  across the chamber.  
Can do a lot with POSINST.

### *But it is hard:*

- width of the resonances (ILC DR wigglers)  $\approx 10$  G  $\Rightarrow$  need z resolution  $\sim 2 \mu\text{m}$ ! Grid cells asymmetric (350:1:1), leading to possible error, or could instead make huge runs by resolving x and y to  $\mu\text{m}$  scale.
- Time step must be  $\sim 1 \times 10^{-11}$  s to resolve beam and cyclotron motion.

From: K. Ohmi, *Coherent effects of electron clouds*

## Combination

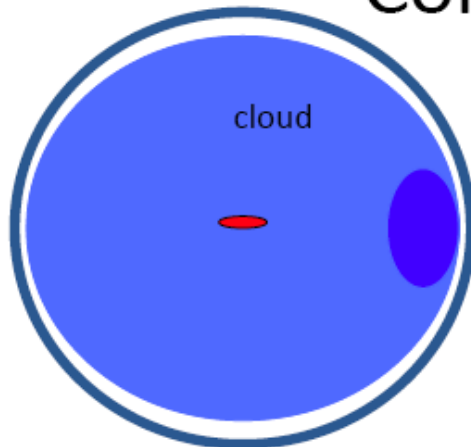

- $\Delta v_y > 0$   $\Delta v_x \sim 0$  can be realized, if  $\Delta v_x$  is cancelled in two distributions.

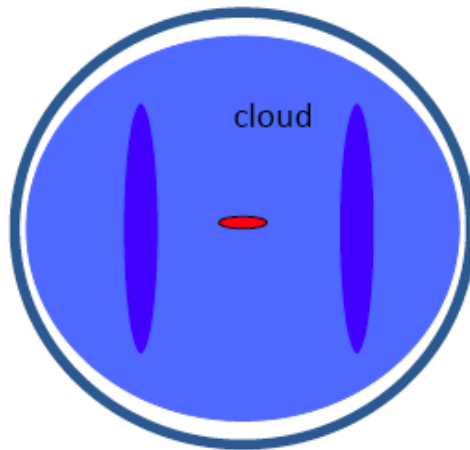

From: M. Furman, *Summary of Working Session on Simulations*



## The 3 aspects of “benchmarking” (1)

- Do the code simulations agree with...
  1. Analytic results whenever they are available (algorithm validation)
  2. Each other (benchmarking)
  3. Measurements (code validation)

### Item 2

- ✓ Understand the influence of rediffused electrons in build up codes
- ✓ Instability codes have been benchmarked several times against each other (HEADTAIL, PEHTS, QuickPIC)

### Item 3

- ✓ Many free input parameters, which can be used to fit the experimental results
- ✓ Long story of qualitative or semi-quantitative agreements (or predictions), both for build up and instability simulations



## Questions, odds and ends

---

- Why does  $\Delta v$  keep increasing after the end of the train with  $e^-$  beams?
  - plausibility argument exists; check it with simulated movies of the ecloud
- Why is  $\Delta v_x \ll \Delta v_y$ ?
  - I thought K. Ohmi provided the answer (ecloud distribution concentrated in the midplane, or 2 clumps of electrons on either side of the center)
  - This argument is operative if ecloud in the machine is dominated by dipoles
- Will the cyclotron resonances (C. Celata) be important in wigglers (3D field)?
  - question will be answered by 3D simulations and RFA measurements in wigglers
- Effect on  $e^-$  survival time due to ions (longer lifetime than otherwise expected)
  - suspicions at SPS and RHIC (?)
- Secondary ionization
  - ionization X-section of residual gas by  $\sim 100$  eV electrons is  $\gg$  than for a  $\sim$ GeV beam
- Surface roughness of extruded Al surface has a preferential direction  $\implies$  SEY depends on  $(\theta, \phi)$ , not simply  $\theta$ 
  - but please: do not attempt an even more complicated SEY model
  - instead, fit beam data with a few effective parameters